

## 0M Series Quarter Turn Actuators



## Wiring Diagrams

## On / Off Control

## Table of Contents

240VAC – 30% Duty Cycle .....	2
Models 0M-1 & 0M-A.....	2
Models 0M-2 to 0M-13.....	3
110VAC – 30% Duty Cycle .....	4
Models 0M-1 & 0M-A.....	4
Models 0M-2 to 0M-13.....	5
24VAC – 75% & 50% Duty Cycles.....	6
Models 0M-1 to 0M-A (75% Duty Cycle).....	6
Models 0M-2 to 0M-13 (0M-2 to 0M-8 →75% Duty, 0M-9 to 0M-13 → 50% Duty).....	7
24VDC – 75% & 50% Duty Cycles.....	8
Models 0M-1 to 0M-A (75% Duty Cycle).....	8
Models 0M-2 to 0M-13 (0M-2 to 0M-8 →75% Duty, 0M-9 to 0M-13 → 50% Duty).....	9
12VDC – 75% & 50% Duty Cycles.....	10
Models 0M-1 to 0M-A (75% Duty Cycle).....	10
Models 0M-2 to 0M-13 (0M-2 to 0M-8 →75% Duty, 0M-9 to 0M-13 → 50% Duty).....	11
415VAC – 30% Duty Cycle .....	12
Models 0M-2 to 0M-13.....	12

## 240VAC – 30% Duty Cycle Models 0M-1 & 0M-A

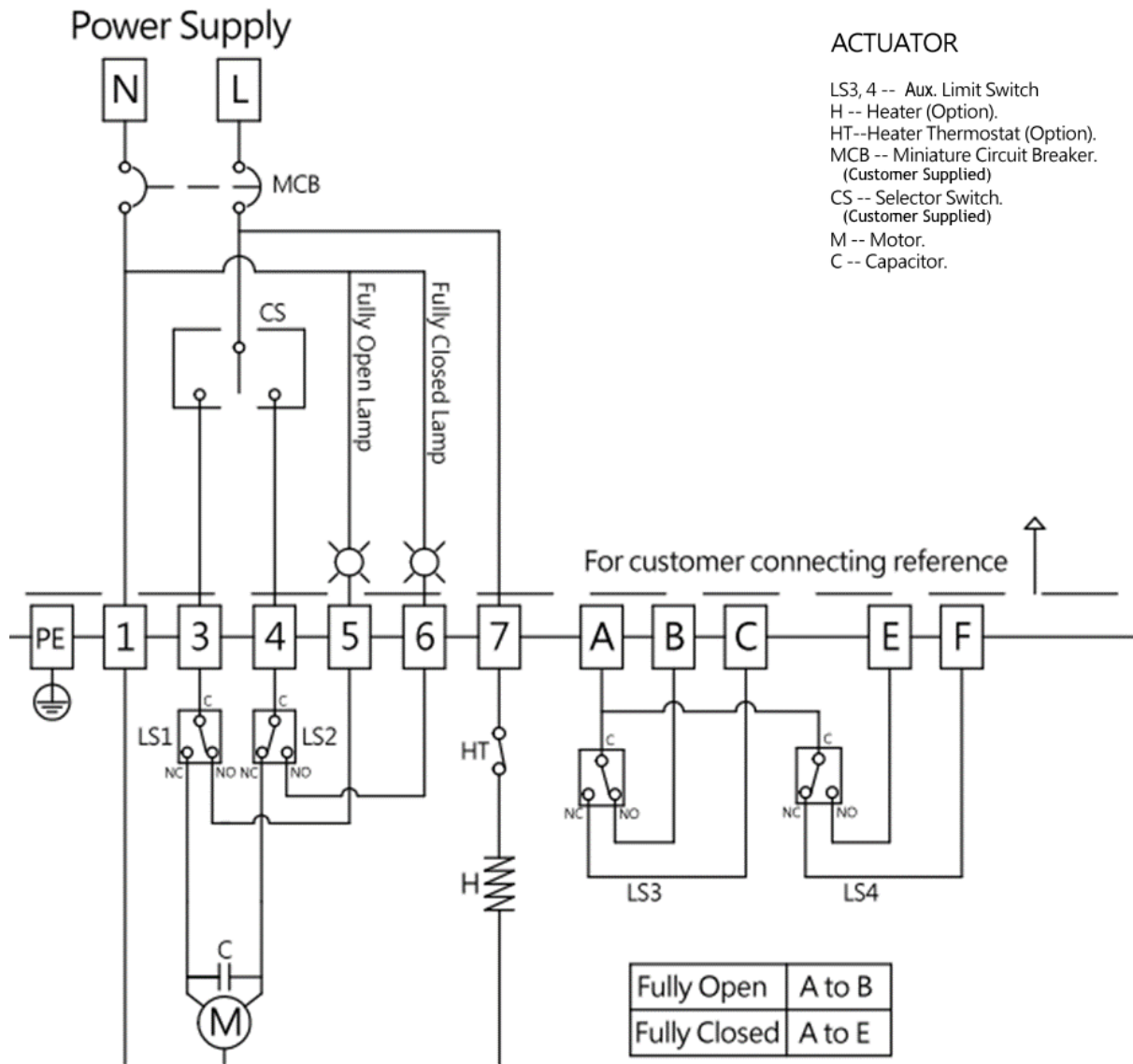

### Notes:

1. Heater (H) & Heater Thermostat (HT) are optional extras, contact Sales.
2. All items above the “Customer Connection Reference” line are for reference only and is recommended for customer to follow best practises and design control elements to suit.
3. “N” connects to terminal 1, “L” connects to terminal 7 .
4. “L” connects to terminal 3 for “OPEN” and to terminal 4 for “CLOSE” (through a switch sourced by customer).
5. Terminal block “A~F” needs to use resistive load and should not exceed 3A at 250VAC.
6. Do not parallel wire multiple actuators together without using an extra relay. Contact sales for optional Isolating Relay Module which can be fitted from factory.

## Models 0M-2 to 0M-13

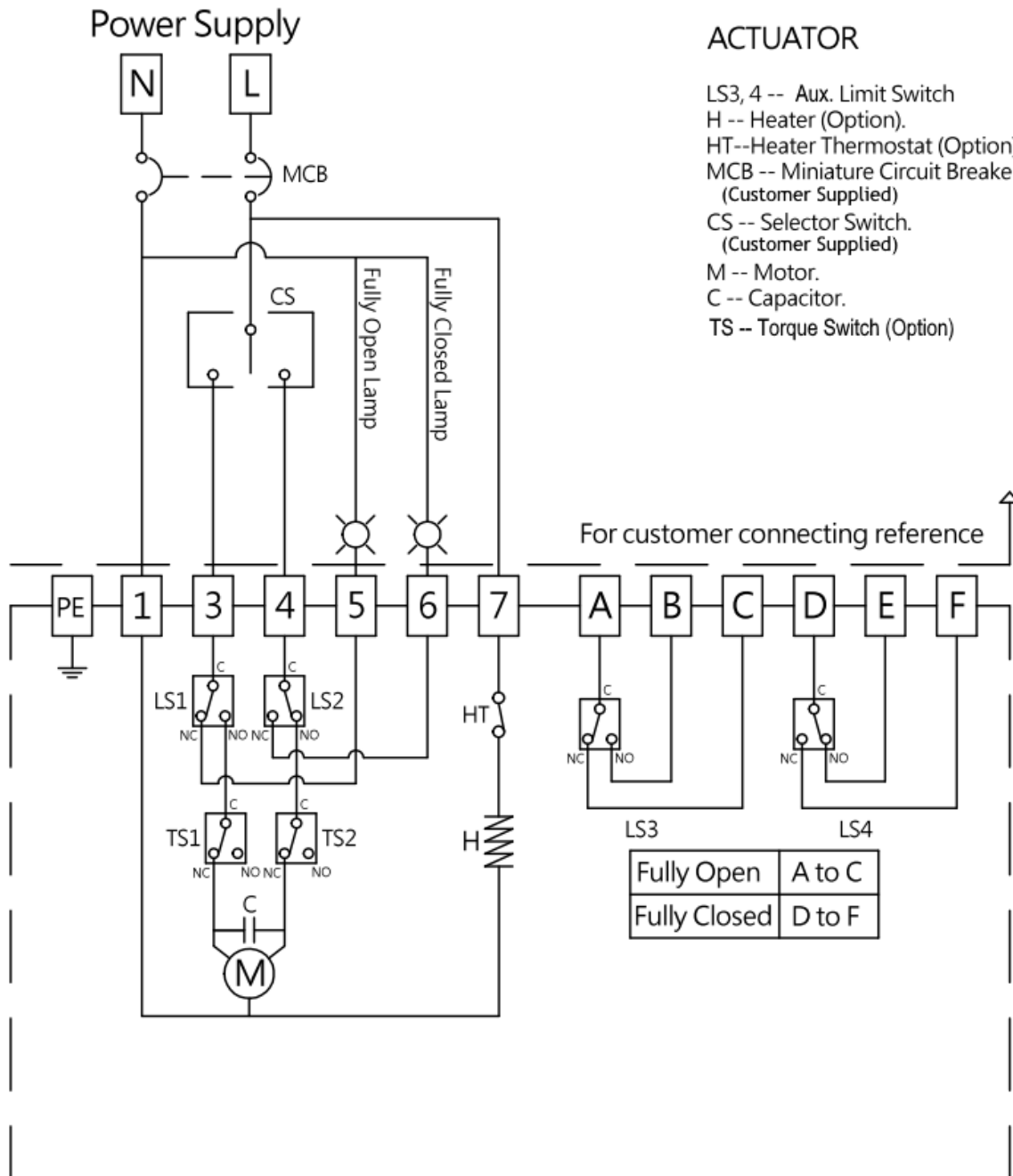

### Notes:

1. Heater (H), Heater Thermostat (HT) & Torque Switch (TS) are optional extras, contact Sales.
2. All items above the “Customer Connection Reference” line are for reference only and is recommended for customer to follow best practises and design control elements to suit.
3. “N” connects to terminal 1, “L” connects to terminal 7 .
4. “L” connects to terminal 3 for “OPEN” and to terminal 4 for “CLOSE” (through a switch sourced by customer).
5. Terminal block “A~F” needs to use resistive load and should not exceed 5A at 250VAC.
6. Do not parallel wire multiple actuators together without using an extra relay. Contact sales for optional Isolating Relay Module which can be fitted from factory.

# 110VAC – 30% Duty Cycle Models 0M-1 & 0M-A

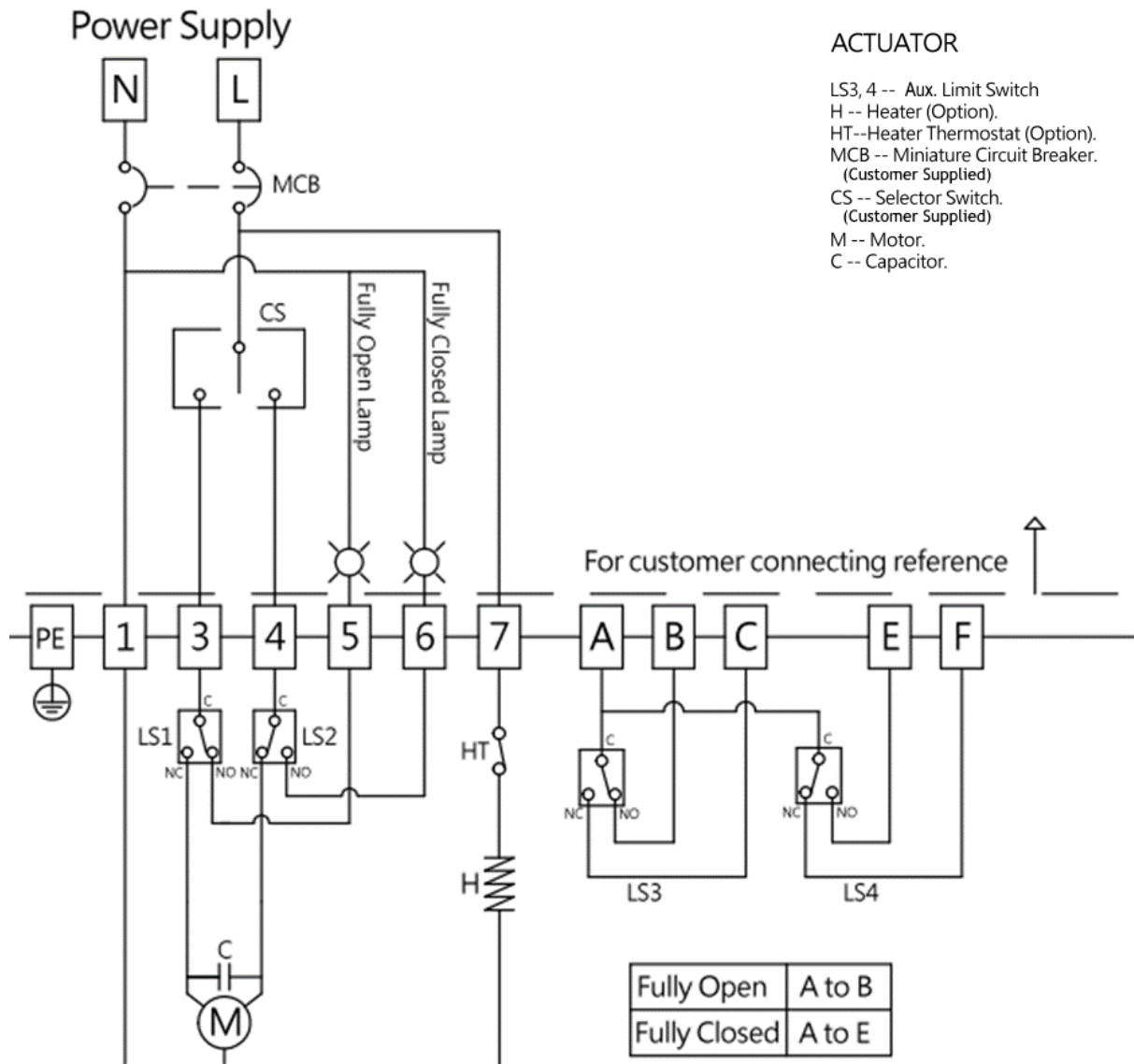

Notes:

1. Heater (H) & Heater Thermostat (HT) are optional extras, contact Sales.
2. All items above the “Customer Connection Reference” line are for reference only and is recommended for customer to follow best practises and design control elements to suit.
3. “N” connects to terminal 1, “L” connects to terminal 7 .
4. “L” connects to terminal 3 for “OPEN” and to terminal 4 for “CLOSE” (through a switch sourced by customer).
5. Terminal block “A~F” needs to use resistive load and should not exceed 3A at 250VAC.
6. Do not parallel wire multiple actuators together without using an extra relay. Contact sales for optional Isolating Relay Module which can be fitted from factory.



## 24VAC – 75% & 50% Duty Cycles Models 0M-1 to 0M-A (75% Duty Cycle)

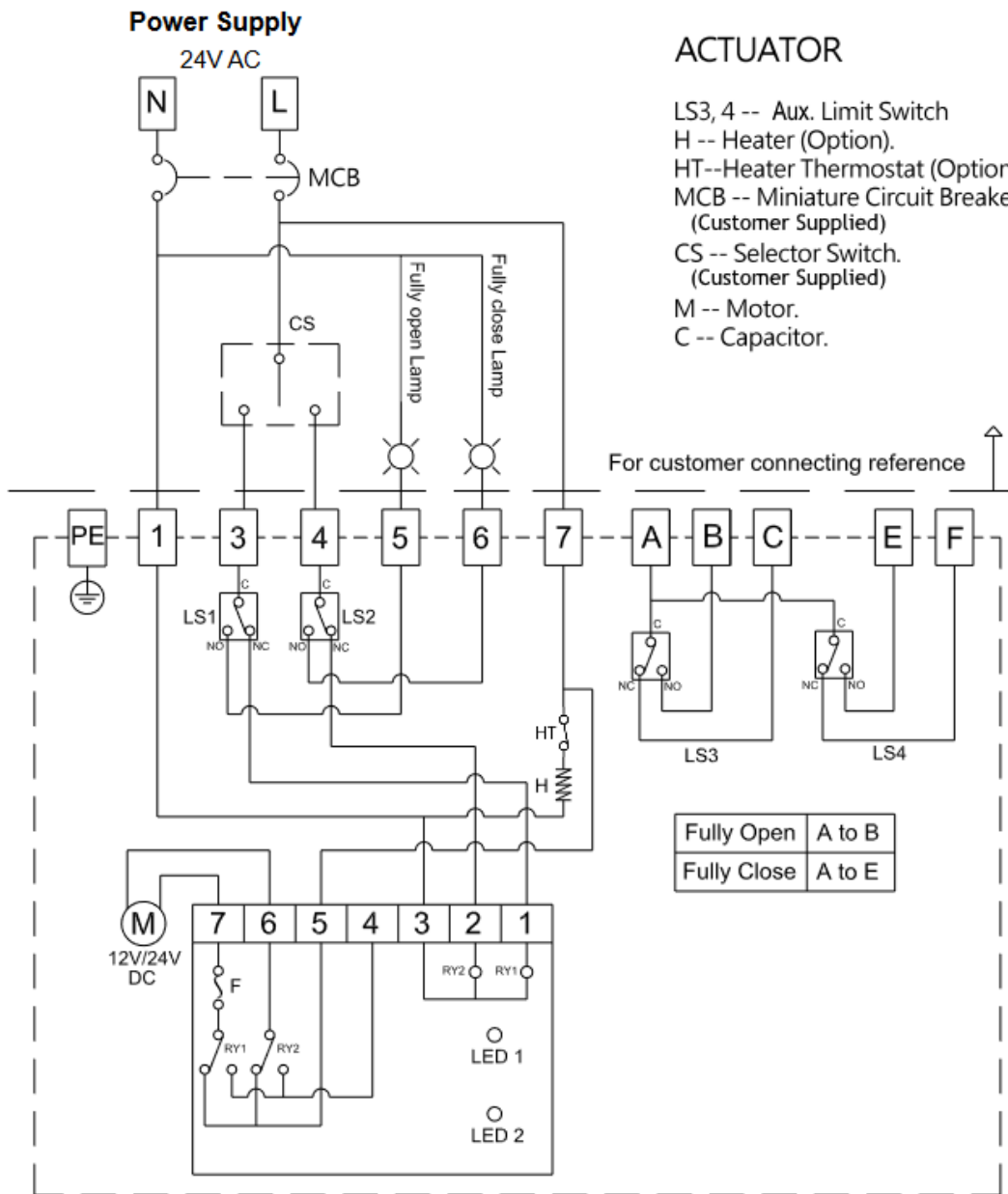

### Notes:

1. Heater (H) & Heater Thermostat (HT) are optional extras, contact Sales.
2. All items above the “Customer Connection Reference” line are for reference only and is recommended for customer to follow best practises and design control elements to suit.
3. “N” connects to terminal 1, “L” connects to terminal 7 .
4. “L” connects to terminal 3 for “OPEN” and to terminal 4 for “CLOSE” (through a switch sourced by customer).
5. Terminal block “A~F” needs to use resistive load and should not exceed 3A at 250VAC.
6. Do not parallel wire multiple actuators together without using an extra relay. Contact sales for optional Isolating Relay Module which can be fitted from factory.

**Models 0M-2 to 0M-13 (0M-2 to 0M-8 →75% Duty, 0M-9 to 0M-13 → 50% Duty)**

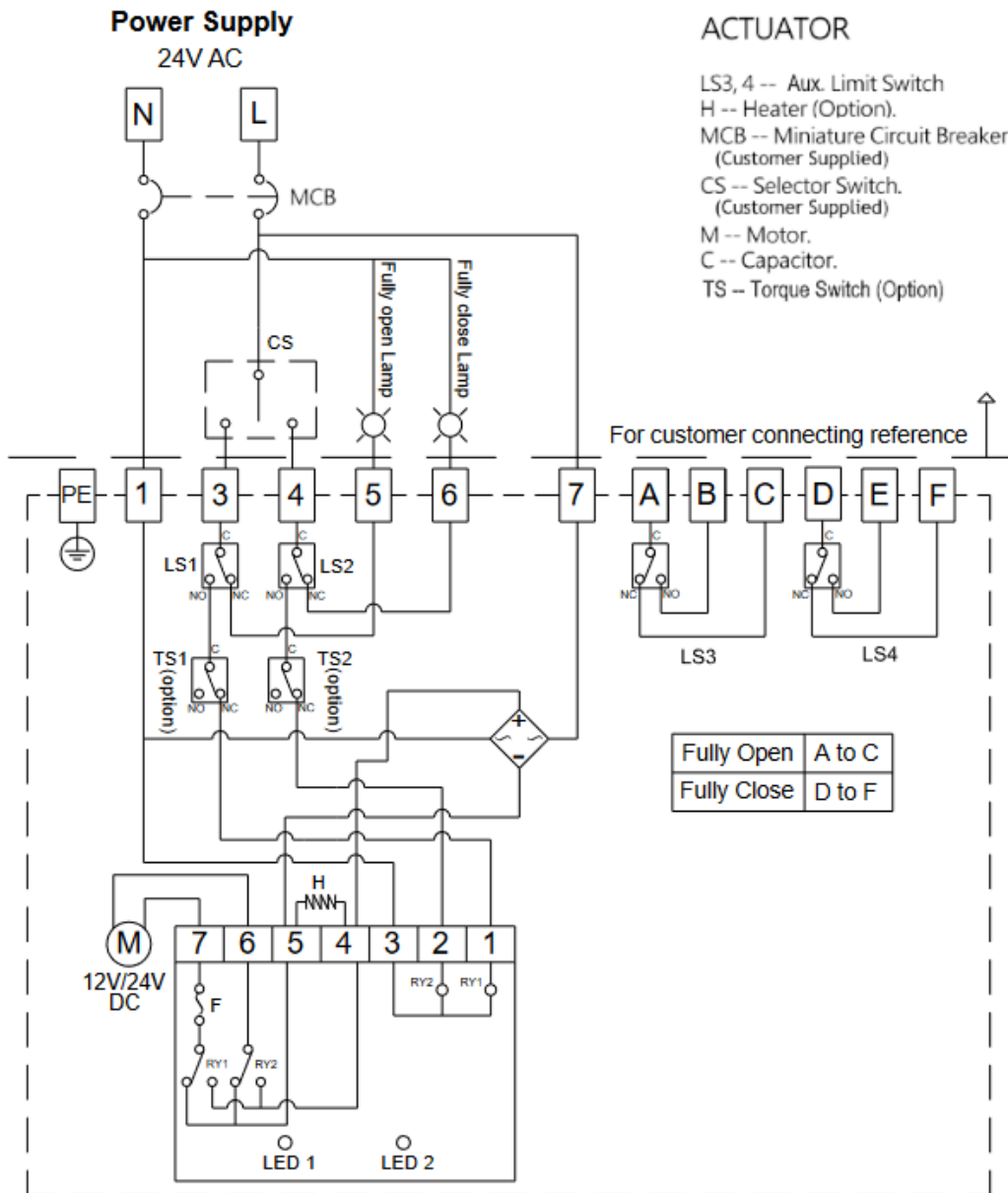

Notes:

1. Heater (H)[with Heater Thermostat] & Torque Switch (TS) are optional extras, contact Sales.
2. All items above the “Customer Connection Reference” line are for reference only and is recommended for customer to follow best practises and design control elements to suit.
3. “N” connects to terminal 1, “L” connects to terminal 7 .
4. “L” connects to terminal 3 for “OPEN” and to terminal 4 for “CLOSE” (through a switch sourced by customer).
5. Terminal block “A~F” needs to use resistive load and should not exceed 5A at 250VAC.
6. Do not parallel wire multiple actuators together without using an extra relay. Contact sales for optional Isolating Relay Module which can be fitted from factory.



## 24VDC – 75% & 50% Duty Cycles Models 0M-1 to 0M-A (75% Duty Cycle)

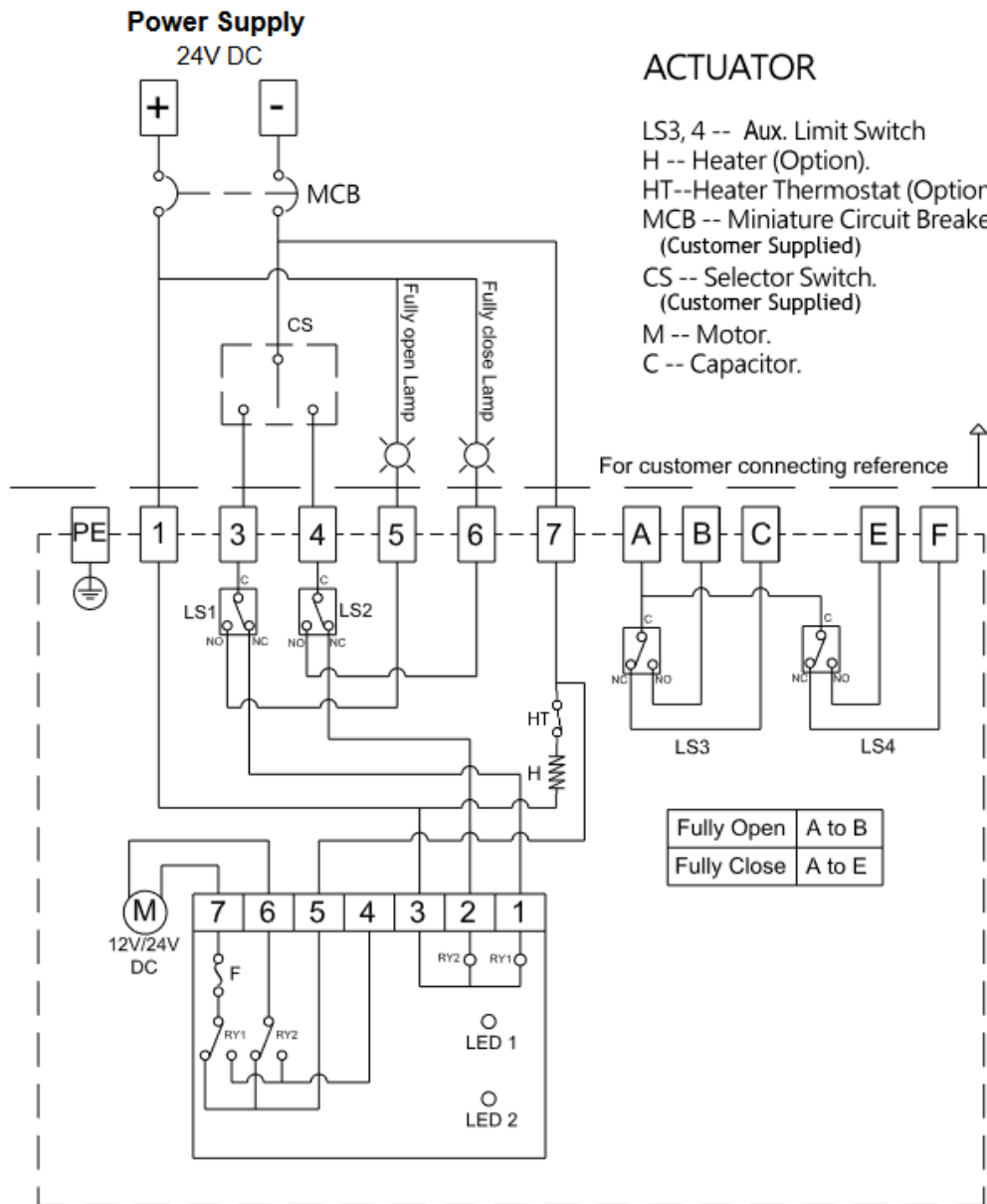

### Notes:

1. Heater (H) & Heater Thermostat (HT) are optional extras, contact Sales.
2. All items above the “Customer Connection Reference” line are for reference only and is recommended for customer to follow best practises and design control elements to suit.
3. “N” connects to terminal 1, “L” connects to terminal 7 .
4. “L” connects to terminal 3 for “OPEN” and to terminal 4 for “CLOSE” (through a switch sourced by customer).
5. Terminal block “A~F” needs to use resistive load and should not exceed 3A at 250VAC.
6. Do not parallel wire multiple actuators together without using an extra relay. Contact sales for optional Isolating Relay Module which can be fitted from factory.

**Models 0M-2 to 0M-13 (0M-2 to 0M-8 → 75% Duty, 0M-9 to 0M-13 → 50% Duty)**

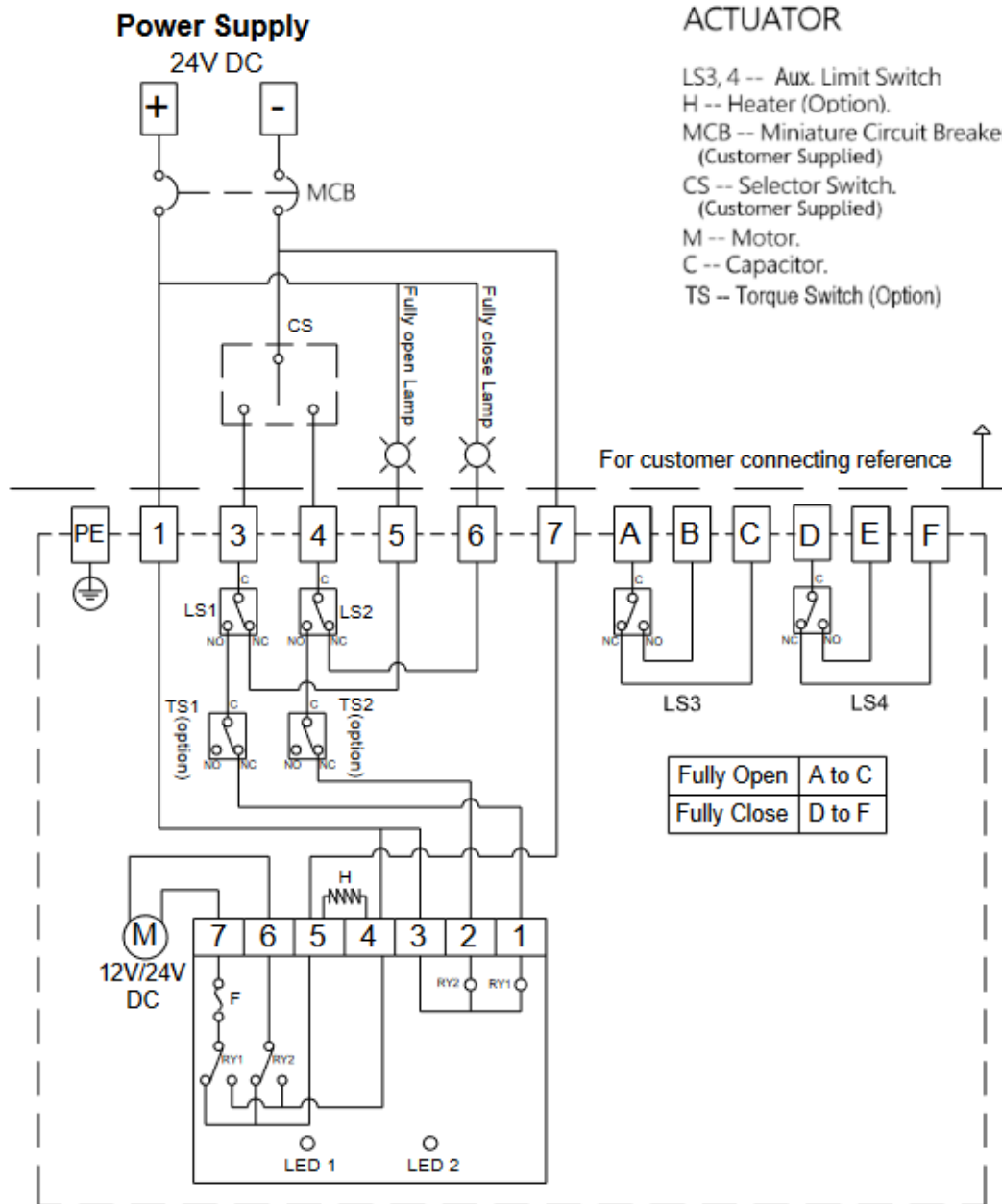

Notes:

1. Heater (H)[with Heater Thermostat] & Torque Switch (TS) are optional extras, contact Sales.
2. All items above the “Customer Connection Reference” line are for reference only and is recommended for customer to follow best practises and design control elements to suit.
3. “N” connects to terminal 1, “L” connects to terminal 7 .
4. “L” connects to terminal 3 for “OPEN” and to terminal 4 for “CLOSE” (through a switch sourced by customer).
5. Terminal block “A~F” needs to use resistive load and should not exceed 5A at 250VAC.
6. Do not parallel wire multiple actuators together without using an extra relay. Contact sales for optional Isolating Relay Module which can be fitted from factory.

## 12VDC – 75% & 50% Duty Cycles Models 0M-1 to 0M-A (75% Duty Cycle)

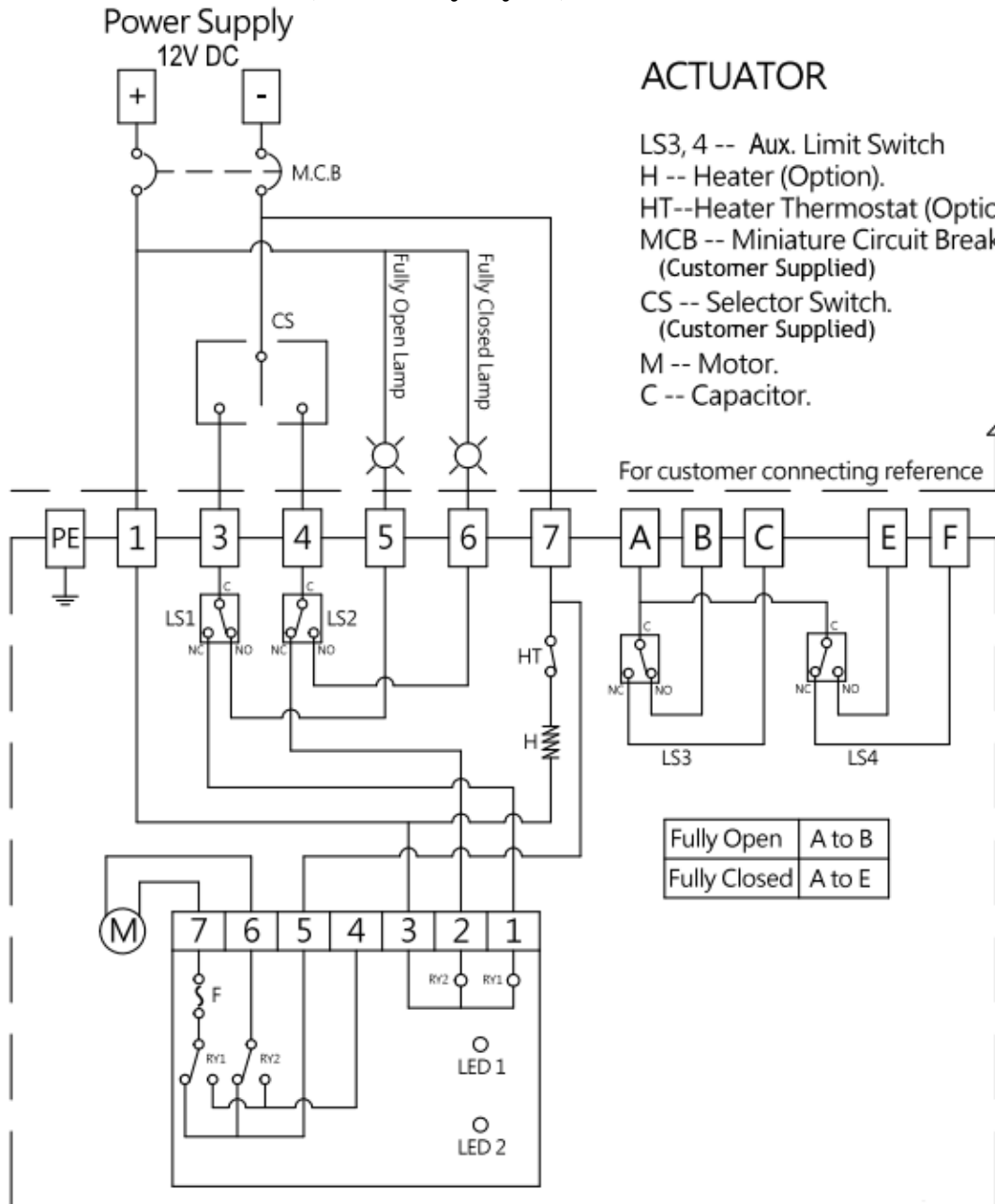

### Notes:

1. Heater (H) & Heater Thermostat (HT) are optional extras, contact Sales.
2. All items above the “Customer Connection Reference” line are for reference only and is recommended for customer to follow best practises and design control elements to suit.
3. “N” connects to terminal 1, “L” connects to terminal 7 .
4. “L” connects to terminal 3 for “OPEN” and to terminal 4 for “CLOSE” (through a switch sourced by customer).
5. Terminal block “A~F” needs to use resistive load and should not exceed 3A at 250VAC.
6. Do not parallel wire multiple actuators together without using an extra relay. Contact sales for optional Isolating Relay Module which can be fitted from factory.

**Models 0M-2 to 0M-13 (0M-2 to 0M-8 → 75% Duty, 0M-9 to 0M-13 → 50% Duty)**

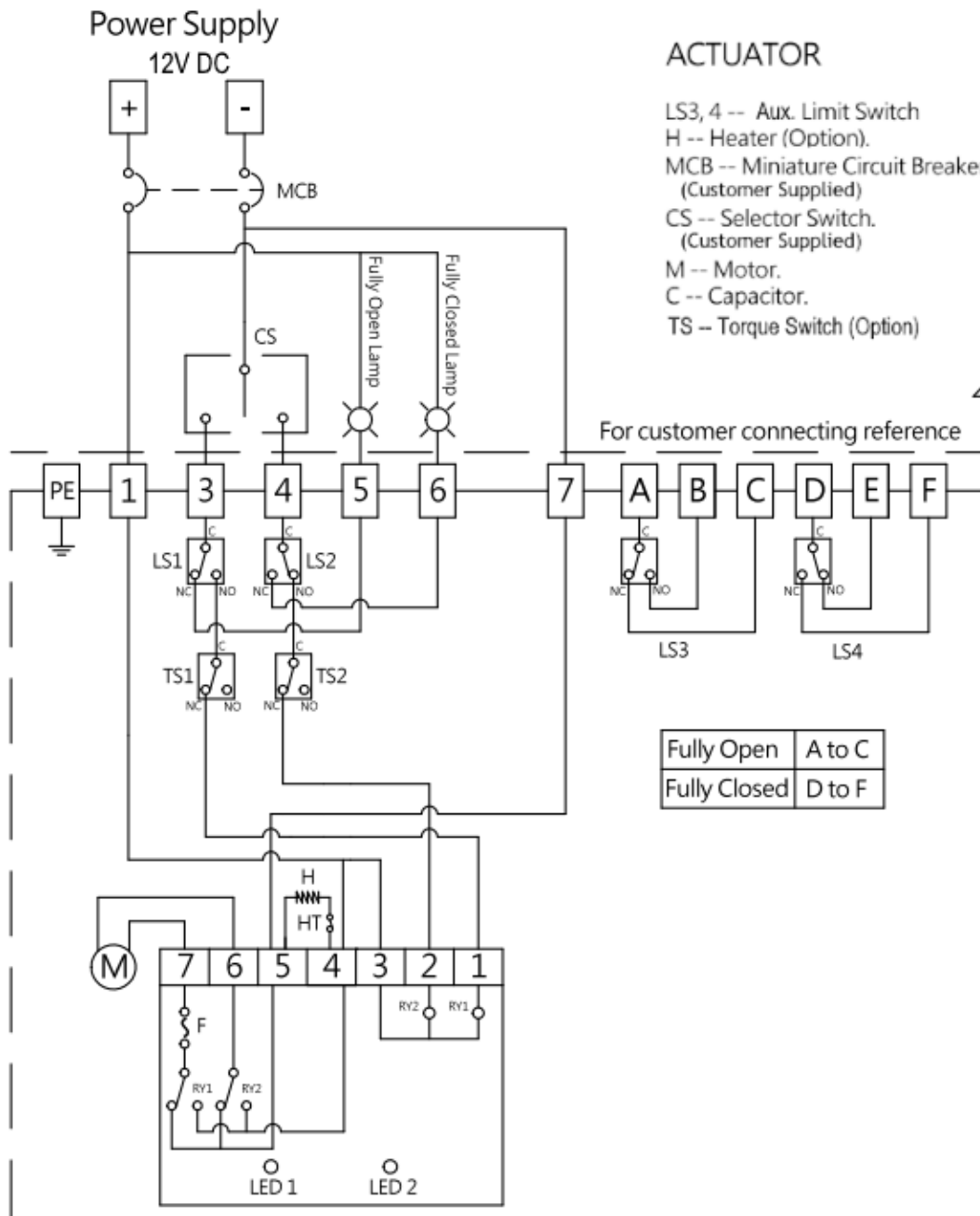

Notes:

1. Heater (H), Heater Thermostat (HT) & Torque Switch (TS) are optional extras, contact Sales.
2. All items above the “Customer Connection Reference” line are for reference only and is recommended for customer to follow best practises and design control elements to suit.
3. “N” connects to terminal 1, “L” connects to terminal 7 .
4. “L” connects to terminal 3 for “OPEN” and to terminal 4 for “CLOSE” (through a switch sourced by customer).
5. Terminal block “A~F” needs to use resistive load and should not exceed 5A at 250VAC.
6. Do not parallel wire multiple actuators together without using an extra relay. Contact sales for optional Isolating Relay Module which can be fitted from factory.

## 415VAC – 30% Duty Cycle Models 0M-2 to 0M-13

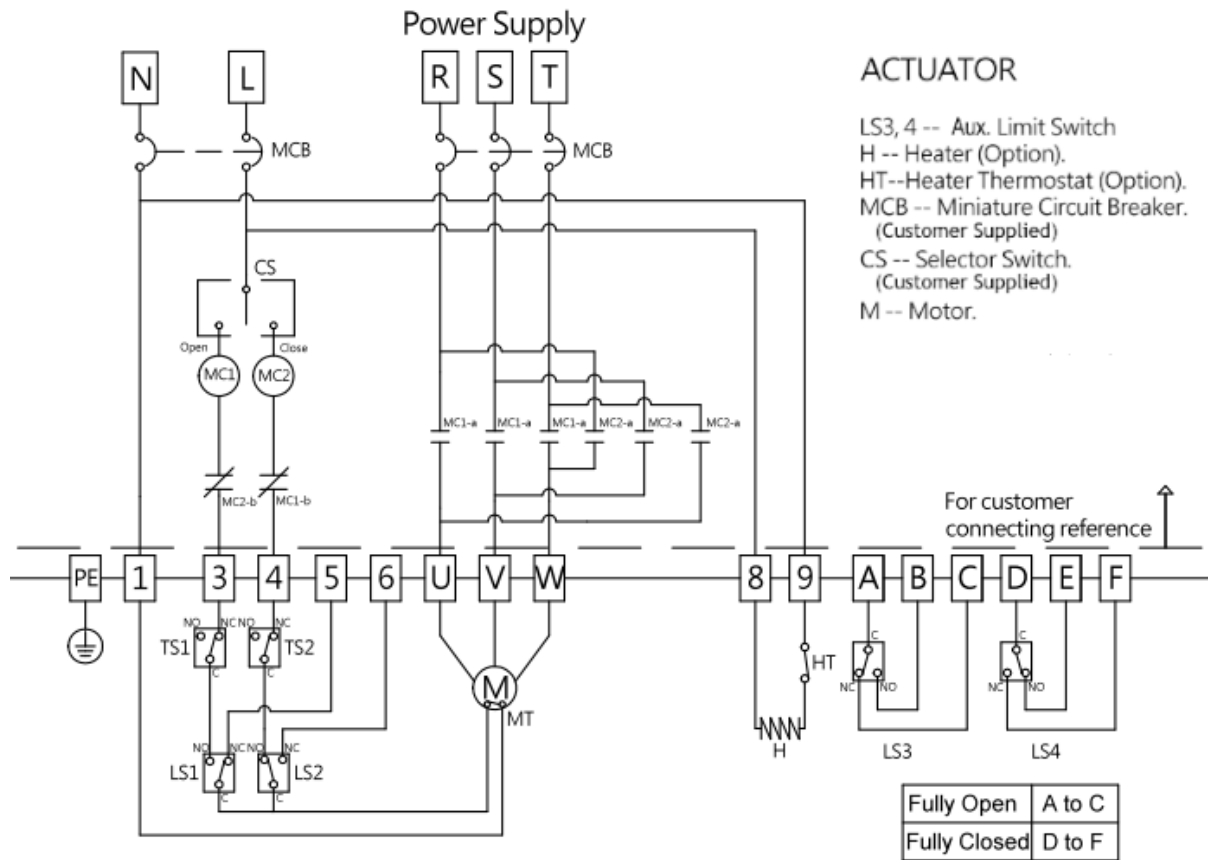

### Notes:

1. Heater (H), Heater Thermostat (HT) & Torque Switch (TS) are optional extras, contact Sales.
2. All items above the “Customer Connection Reference” line are for reference only and is recommended for customer to follow best practises and design control elements to suit.
3. Terminal block “A~F” needs to use resistive load and should not exceed 5A at 250VAC.
4. Use the handwheel to turn the actuator to 45 degrees before testing operation. If the operating direction is opposite, please change and two of R, S, T.

System designers and end users are cautioned to review specific warnings or specifications found instruction sheets or labels packed or attached and shipped with the goods. Through misuse, age, or malfunction, components used in industrial valve applications can fail in various modes. The system designer is warned to consider the failure modes of all component parts used in industrial applications and to provide adequate safeguards to prevent personal injury or damage to equipment in the event of such failure. Our policy is one of continuous research and Development. We therefore reserve the right to amend without notice specifications given in this document or individual series data sheets.